



Outdoor Unit	Model of Outdoor Unit		GWH09AGA-K6DNA1A/O	GWH12AGB-K6DNA1A/O
	Product Code of Outdoor Unit		CB385W01000	CB385W01700
	Compressor Manufacturer/Trademark		ZHUHAI LANDA COMPRESSOR CO.,LTD	ZHUHAI LANDA COMPRESSOR CO., LTD
	Compressor Model		FTz-AN075ACBF-A	FTz-AN088ACBF-A
	Compressor Oil		FW68DA	FW68DA
	Compressor Type		Rotary	Rotary
	L.R.A.	A	20.00	/
	Compressor RLA	A	3.00	3.60
	Compressor Power Input	W	633	758
	Overload Protector		/	/
	Throttling Method		Capillary	Capillary
	Operation Temp	°C	16~30	16~30
	Ambient Temp (Cooling)	°C	-15~43	18~43
	Ambient Temp (Heating)	°C	-15~24	-15~24
	Condenser Form		Aluminum Fin-copper Tube	Aluminum Fin-copper Tube
	Pipe Diameter	mm	Φ7	Φ7
	Rows-fin Gap	mm	1-1.4	1-1.4
	Coil Length (LXDXW)	mm	700X19.05X528	700X19.05X528
	Fan Motor Speed	rpm	900	900
	Output of Fan Motor	W	30	30
	Fan Motor RLA	A	0.40	0.40
	Fan Motor Capacitor	μF	/	/
	Air Flow Volume of Outdoor Unit	m <sup>3</sup> /h	2200	2200
	Fan Type		Axial-flow	Axial-flow
	Fan Diameter	mm	Φ400	Φ400
	Defrosting Method		Automatic Defrosting	Automatic Defrosting
	Climate Type		T1	T1
	Isolation		I	I
	Moisture Protection		IPX4	IPX4
	Permissible Excessive Operating Pressure for the Discharge Side	MPa	4.3	4.3
	Permissible Excessive Operating Pressure for the Suction Side	MPa	2.5	2.5
	Sound Pressure Level (H/M/L)	dB (A)	51/-/-	51/-/-
Sound Power Level (H/M/L)	dB (A)	62/-/-	64/-/-	
Dimension (WXHXD)	mm	732X550X330	732X550X330	
Dimension of Carton Box (LXWXH)	mm	789X390X600	789X390X600	
Dimension of Package (LXWXH)	mm	792X393X615	792X393X615	
Net Weight	kg	25	25	
Gross Weight	kg	27.5	27.5	
Refrigerant		R32	R32	
Refrigerant Charge	kg	0.5	0.55	
Connection Pipe	Length	m	5	5
	Gas Additional Charge	g/m	16	16
	Outer Diameter Liquid Pipe	inch	1/4	1/4
	Outer Diameter Gas Pipe	inch	3/8	3/8
	Max Distance Height	m	10	10
	Max Distance Length	m	15	15
	Note: The connection pipe applies metric diameter.			

The above data is subject to change without notice; please refer to the nameplate of the unit.





### 3.2 Outdoor Unit

09/12K

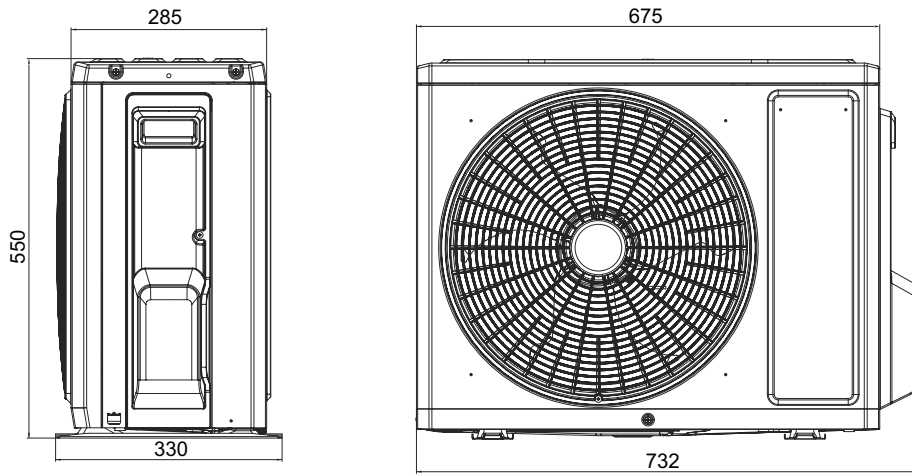

Unit:mm

18K

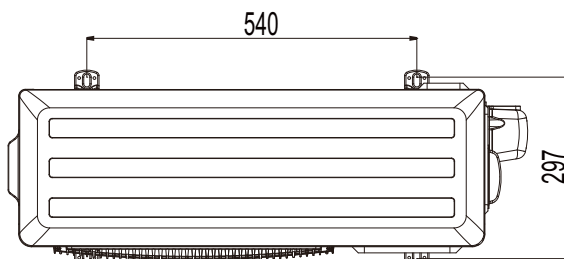
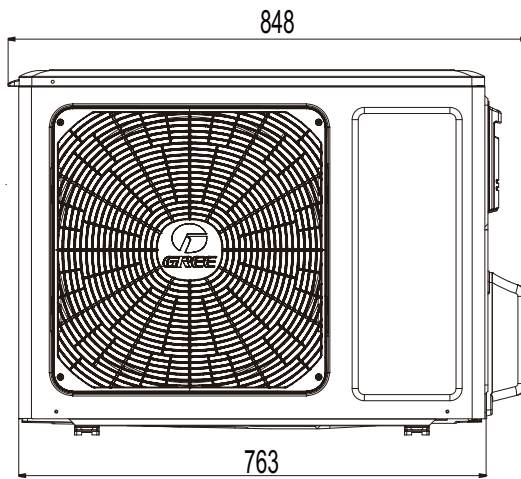

Unit:mm